

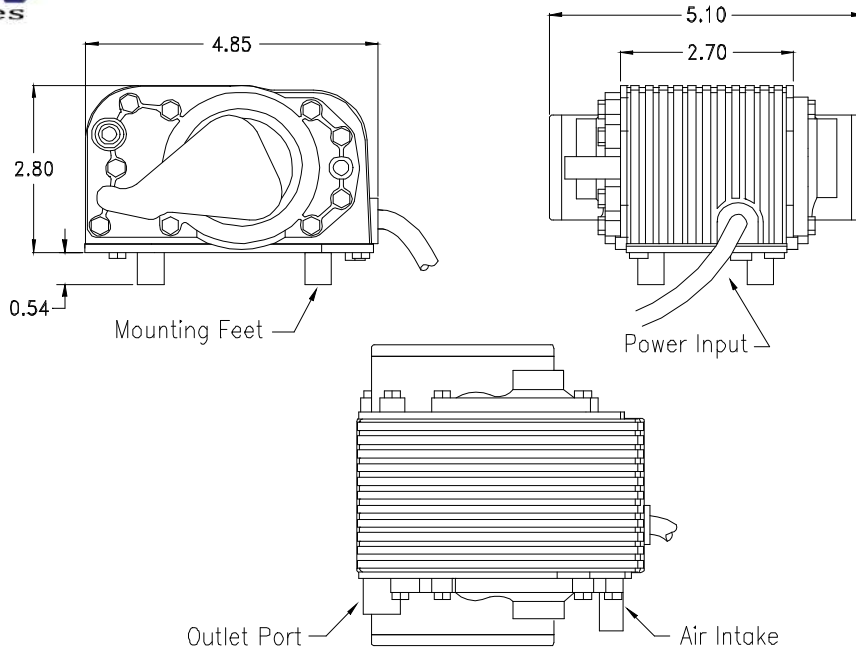

PUMP SPECIFICATIONS MODEL 7000



SPECIFICATIONS:

MODEL NUMBER: APOLLO 7000

PUMP DESIGN: DOUBLE DIAPHRAGM, SINGLE OUTLET, OSCILLATING LINEAR MOTION

NET WEIGHT: 3.3 LBS.

PUMPED MEDIAS: AIR AND GASES COMPATIBLE WITH MATERIALS OF CONSTRUCTION

PORTS: OUTLET IS FEMALE, ACCEPTS 1/8 NPT FITTING. AIR INTAKE ACCEPTS 5/16" ID TUBING (PRESSED ON).

MOUNTING: RUBBER MOUNTING FEET WITH THREADED INSERTS. ACCEPTS FOUR #8 SCREWS IN 2.8" X 1.75" RECTANGULAR PATTERN

OPERATING TEMPERATURE: 30 to 105 DEGREES F, (-1 to 41 DEGREES C)

MATERIALS OF CONSTRUCTION:

- PUMP BODY: ALUMINUM
- DIAPHRAGMS: RUBBER
- VALVES: SILICONE
- FASTENERS: STEEL

MOTOR: FIXED COIL, OSCILLATING CONNECTING ROD, 60 Hz NATURAL FREQUENCY

ELECTRICAL CONNECTIONS: 18" INSULATED WIRE PAIR

ELECTRICAL SPECIFICATIONS (TYPICAL):

- VOLTAGE: 115VAC, 60 Hz
- CURRENT: 0.40 AMPS MAX.
- POWER: 30.0 WATTS @ OPEN FLOW, 24.0 WATTS @ 2.0 PSI

NOISE LEVEL: 67dB UNCONNECTED, CONNECTED OPERATION WILL REDUCE dB LEVEL.

TYPICAL PERFORMANCE:

PRESSURE -PSI	0	0.5	1.0	2.0	3.0	5.5
FLOW - SCFH	95.0	80.0	42.0	23.0	15.0	0.0
FLOW - LTR/MIN	44.7	37.6	19.7	10.8	7.1	0.0

APOLLO ENTERPRISES 3007 BUNSEN AVE., SUITE A VENTURA, CA 93003
TELEPHONE (805) 644-1504, 1-800-873-1399, FAX (805) 644-1507 Visit us at www.apollopumps.com