

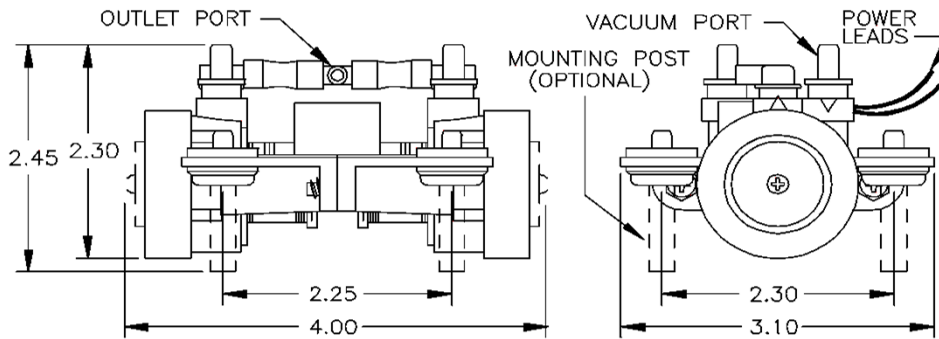

PUMP SPECIFICATIONS MODEL V5000



SPECIFICATIONS:

MODEL NUMBER: APOLLO V5000

PUMP DESIGN: DOUBLE DIAPHRAGM, DUCKBILL VALVES

NET WEIGHT: 12oz (WITHOUT ENCLOSURE)

PUMPED MEDIAS: AIR AND GASES COMPATIBLE WITH MATERIALS OF CONSTRUCTION

PORTS: INLET: .20" OD X .30" L SMOOTH ELBOW

OUTLET: .20" OD X .30" L SMOOTH ELBOW

OPERATING TEMPERATURE: 30 to 105 DEGREES FAHRENHEIT

MATERIALS OF CONSTRUCTION:

PUMP BODY: ACETAL

DIAPHRAGMS: THERMO-PLASTIC ELASTOMER (STD), NATURAL RUBBER, SANTOPRENE, EPDM (OPTIONAL)

VALVES: SILICONE

FASTENERS: PLATED STEEL

ENCLOSURES : ABS

ENCLOSURE DIMENSIONS 5.3" L X 4.0" W X 2.70" H (STANDARD)

MOTOR: FIXED COIL, OSCILLATING MAGNET 60Hz NATURAL FREQUENCY

ELECTRICAL CONNECTIONS: 170" WIDTH SOLDER TERMINALS

ELECTRICAL SPECIFICATIONS (TYPICAL):

5 WATTS POWER, +/- 10%; CURRENT RATINGS BELOW

VOLTAGE	6 VDC	9 VDC	12 VDC	24 VDC	12 VAC	24 VAC	115 VAC	220 VAC
CURRENT AMPS*	1.25	0.85	0.62	0.32	0.75	0.37	0.075	0.041

* CURRENT VALUES TYPICAL DC VOLTAGES REQUIRE INVERTER CIRCUITRY

PERFORMANCE:

VACUUM - IN. H2O	0	5	10	15	20	25	30.0	35	40.0	45.0	50.0	62.0
FLOW - SCFH	11.0	7.6	6.5	5.6	5.4	4.1	3.4	2.3	1.8	1.0	<1	0
FLOW - LTR/MIN	5.2	3.6	3.1	2.6	2.5	1.9	1.6	1.1	0.85	0.47	<.4	0

APOLLO ENTERPRISES 3007 BUNSEN AVE., SUITE A VENTURA, CA 93003

TELEPHONE (805) 644-1504, 1-800-873-1399, FAX (805) 644-1507

Visit us at www.apollopumps.com

08/26/19