

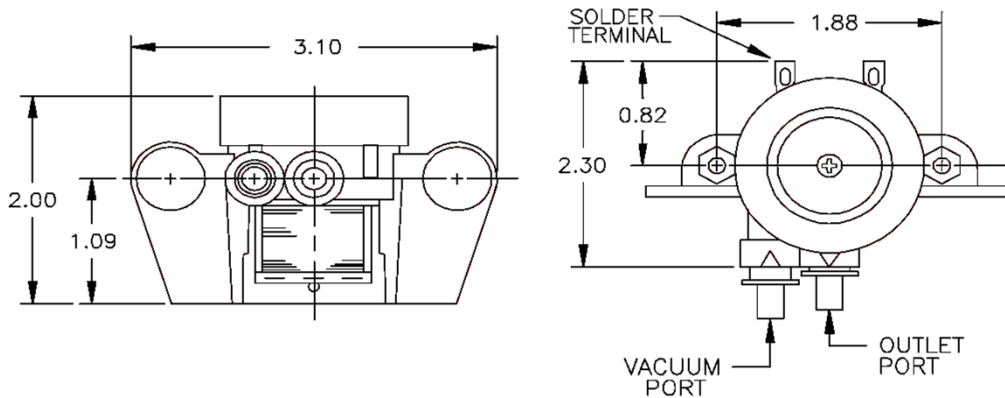

SPECIFICATIONS MODEL V3000



SPECIFICATIONS:

MODEL NUMBER: APOLLO V3000

PUMP DESIGN: SINGLE DIAPHRAGM, DUCKBILL VALVES

NET WEIGHT: 5 OZ (WITHOUT ENCLOSURE)

PUMPED MEDIAS: AIR AND GASES COMPATIBLE WITH MATERIALS OF CONSTRUCTION

PORTS: OUTLET .200 OD X .300 L SMOOTH STRAIGHT NIPPLE, ELBOW OPTIONAL
INLET SAME AS ABOVE

OPERATING TEMPERATURE: 30 to 105 DEGREES FAHRENHEIT

MATERIALS OF CONSTRUCTION:

PUMP BODY: ACETAL

DIAPHRAGMS: THERMO-PLASTIC ELASTOMER (STD), NATURAL RUBBER, SANTOPRENE, EPDM (OPTIONAL)

VALVES: SILICONE

FASTENERS: PLATED STEEL

ENCLOSURES: ABS

ENCLOSURE DIMENSIONS: 4.25"L X 3.50" W X 2.80" H

MOTOR: FIXED COIL, OSCILLATING MAGNET 60Hz NATURAL FREQUENCY

ELECTRICAL CONNECTIONS: 170" WIDTH SOLDER TERMINALS

ELECTRICAL SPECIFICATIONS (TYPICAL):

3 WATTS POWER, +/-10% CURRENT RATINGS BELOW:

VOLTAGE	6 VDC	9 VDC	12 VDC	24 VDC	12 VAC	24 VAC	115 VAC	220 VAC
CURRENT AMPS	0.70	0.41	0.35	0.18	0.37	0.18	.037	.018

* CURRENT VALUES TYPICAL DC VOLTAGES REQUIRE INVERTER CIRCUITRY

PERFORMANCE

VACUUM - IN H2O	0	5	10	15	20	30	40	60*
FLOW - SCFH	7.0	4.4	3.8	3.5	3.2	2.5	1.3	0
FLOW - LTR/MIN	3.3	2.1	1.8	1.6	1.5	1.2	0.6	0

* REQUIRES SOLID MOUNT

APOLLO ENTERPRISES 3007 BUNSEN AVE., SUITE A VENTURA, CA 93003

TELEPHONE (805) 644-1504, 1-800-873-1399, FAX (805) 644-1507

Visit us at www.apollopumps.com