

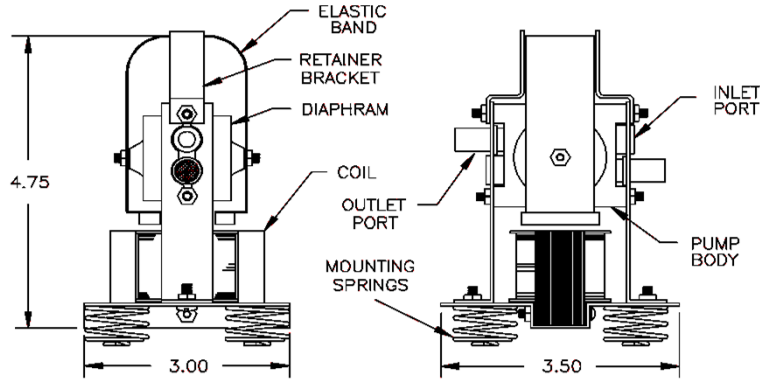

PUMP SPECIFICATIONS MODEL 6000



SPECIFICATIONS:

MODEL NUMBER: APOLLO 6000

PUMP DESIGN: EXTERNAL BAND, DOUBLE DIAPHRAGM, DUCKBILL VALVES

NET WEIGHT: 1 lb. (WITHOUT ENCLOSURE)

PUMPED MEDIAS: AIR AND GASES COMPATIBLE WITH MATERIALS OF CONSTRUCTION

PORTS: OUTLET - STRAIGHT NIPPLE (UNBARBED) .200" OD x .300"L

INLET - 5 MICRON FILTER, NIPPLES (OPTIONAL)

OPERATING TEMPERATURE: 30 to 105 DEGREES FAHRENHEIT

MOUNTING: 4 SPRING MOUNTS (REMOVABLE), WILL ACCEPT #6 OR #8 HARDWARE

MATERIALS OF CONSTRUCTION:

- PUMP BODY:** ACETAL
- DIAPHRAGMS:** EPDM RUBBER
- VALVES:** SILICONE
- FASTENERS:** PLATED STEEL
- ELASTIC BAND:** STAINLESS STEEL

ENCLOSURE INSIDE DIMENSIONS: (MINIMUM) 3.5" LENGTH X 4.0 " WIDE X 5.5" HEIGHT

MOTOR: FIXED COIL, OSCILLATING BAND WITH MAGNETS

ELECTRICAL CONNECTIONS: TERMINALS EXTRUDING FROM TOP OF COIL

ELECTRICAL SPECIFICATIONS (TYPICAL):

15.5 WATTS POWER (STANDARD), +/- 10%, CURRENT RATINGS BELOW

VOLTAGE	6 VDC	9 VDC	12 VDC	24 VDC	12 VAC	24 VAC	115 VAC	220 VAC
CURRENT AMPS	2.5	1.88	1.25	0.63	2.0	1.0	0.20	0.11

* CURRENT VALUES TYPICAL DC VOLTAGES REQUIRE INVERTER CIRCUITRY

TYPICAL PERFORMANCE:

PRESSURE -PSI	0.0	.50	1.0	1.5	2.0	2.5	3.0	3.5	4.0	4.5	5.0
FLOW - SCFH	25.0	12.5	11.6	11.0	10.8	9.8	8.5	6.8	4.5	2.3	0.0
FLOW - LTR/MIN	11.7	5.8	5.4	5.1	5.0	4.6	4.0	3.2	2.1	1.0	0.0

APOLLO ENTERPRISES 3007 BUNSEN AVE., SUITE A VENTURA, CA 93003

TELEPHONE (805) 644-1504, 1-800-873-1399, FAX (805) 644-1507

Visit us at www.apollopumps.com