

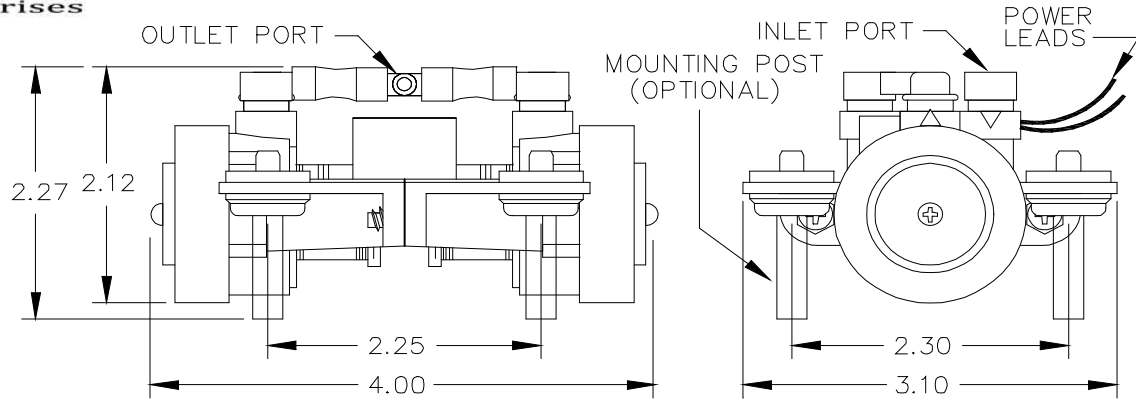

PUMP SPECIFICATIONS MODEL 5000



SPECIFICATIONS:

MODEL NUMBER: APOLLO 5000

PUMP DESIGN: DOUBLE DIAPHRAGM, DUCKBILL VALVES

NET WEIGHT: 10oz (WITHOUT ENCLOSURE)

PUMPED MEDIAS: AIR AND GASES COMPATIBLE WITH MATERIALS OF CONSTRUCTION

PORTS: **OUTLET** .200 OD X .300 L SMOOTH STRAIGHT NIPPLE, ELBOW OPTIONAL

INLET 5 MICRON FILTER, NIPPLES OPTIONAL

OPERATING TEMPERATURE: 30 to 105 DEGREES FAHRENHEIT

MATERIALS OF CONSTRUCTION:

PUMP BODY: ACETAL

DIAPHRAGMS: THERMO-PLASTIC ELASTOMER (STD), NATURAL RUBBER, SANTOPRENE, EPDM (OPTIONAL)

VALVES: SILICONE

FASTENERS: PLATED STEEL

ENCLOSURES : ABS

ENCLOSURE DIMENSIONS: 5.3" L X 4.0" W X 2.70" H (STANDARD)

MOTOR: FIXED COIL, OSCILLATING MAGNET 60Hz NATURAL FREQUENCY

ELECTRICAL CONNECTIONS: 170" WIDTH SOLDER TERMINALS

ELECTRICAL SPECIFICATIONS (TYPICAL):

5.5 WATTS POWER, +/- 10%; CURRENT RATINGS BELOW

VOLTAGE	6 VDC	9 VDC	12 VDC	24 VDC	12 VAC	24 VAC	115 VAC	220 VAC
CURRENT AMPS	1.25	0.85	0.62	0.32	0.75	0.37	0.075	0.041

* CURRENT VALUES TYPICAL DC VOLTAGES REQUIRE INVERTER CIRCUITRY

TYPICAL PERFORMANCE: WITH TPE DIAPHRAGMS

PRESSURE -PSI	0	.5	1.0	1.5	2.0	2.5	3.0
FLOW - SCFH	12.0	6.6	5.3	4.0	2.4	1.0	0
FLOW - LTR/MIN	5.6	3.1	2.5	1.9	1.1	0.5	0

WITH NATURAL RUBBER DIAPHRAGMS

PRESSURE -PSI	0	.50	1.0	1.5	2.0	2.5	3.0	4.5
FLOW - SCFH	13.0	7.5	6.1	4.9	3.8	2.5	1.5	0
FLOW - LTR/MIN	6.1	3.5	2.8	2.3	1.7	1.1	0.7	0

APOLLO ENTERPRISES 3007 BUNSEN AVE., SUITE A VENTURA, CA 93003

TELEPHONE (805) 644-1504, 1-800-873-1399, FAX (805) 644-1507

Visit us at www.apollopumps.com